

The Mechanics of Multi-Joint Posture and Movement Control

Neville Hogan

Department of Mechanical Engineering, Massachusetts Institute of Technology, Cambridge, MA 02139, USA

Abstract. The dependence of muscle force on muscle length gives rise to a "spring-like" behavior which has been shown to play a role in the execution of single-joint posture and movement. This paper extends this concept and considers the influence of the apparent mechanical behavior of the neural, muscular and skeletal system on the control and coordination of multiple degree of freedom posture and movement.

A rigorous definition of "spring-like" behavior is presented. From it a numerically quantifiable, experimental test of spring-like behavior is formulated. It is shown that if the steady-state force-displacement behavior of a limb is not spring-like, this can only be due to the action of inter-muscular feedback, and can not be due to intrinsic muscle properties. The directional character of the spring-like behavior of a multiple degree of freedom system is described. The unique way in which synergistic coactivation of polyarticular muscles may modulate the directional properties of the spring-like behavior of a multiple degree of freedom system is explained.

Dynamic aspects of postural behavior are also considered. The concept of mechanical impedance is presented as a rigorous dynamic generalisation of the postural stiffness of the limb. The inertial behavior of the system is characterised by its mobility. As with the stiffness or impedance, in the multiple degree of freedom case it has a directional property. The way in which the apparent kinematic redundancy of the musculo-skeletal system may be used to modify its dynamic behavior is explained. Whereas the inertial behavior of a single limb segment is not modifiable, it is shown that the apparent inertial behavior of a multiple degree of freedom system may be modulated by repositioning the joints.

A unified description of the posture and movement of a multi-joint system is presented by defining a "virtual trajectory" of equilibrium positions for the limb which may be specified by the neuro-muscular system. The way in which this approach may lead to a simplification of some the apparent computational difficulties associated with the control of multi-joint motion is discussed.

Many neurophysiological studies of the control of posture and movement have focused on one degree of freedom systems such as a single muscle or a single joint. Although there are sound practical reasons for this narrow focus, it is quite difficult to develop a general and fundamental understanding of natural movement control from these studies. Single degree of freedom motions are rare under physiological conditions and do not provide any opportunity to study the complex interactions typical of normal movements. Multiple degree of freedom movements are more natural and provide a richer field of study. In producing them, the central nervous system can not simply string together one degree of freedom movements but must address (and solve) problems of coordination, timing and interaction between different neural, muscular and skeletal structures; hence their study may afford significant insight into the organisation of movement control in the central nervous system. The object of this paper is to consider how some observations on single degree of freedom systems may be generalised and extended to describe the control and coordination of multiple degree of freedom posture and movement. It will be shown that in the multiple degree of freedom case new behavioral possibilities emerge. Some new insights into the possible role and function of some neuro-musculo-skeletal structures will be presented. Some new experiments are

suggested which may elucidate the way the central nervous system coordinates and controls posture and movement. The results of some of these experiments are presented in a paper by Mussa-Ivaldi et al. (1984).

It is probably a truism to say that the mechanical properties of the neuro-muscular system play a significant role in the control of posture and movement. One of the more prominent features of muscle mechanics is the increase of steady-state output force which accompanies muscle stretch (Gordon et al., 1966; Matthews, 1959; Rack and Westbury, 1969). This length-dependence of muscle force (which is due to both reflex action and the molecular mechanics of muscle contraction) gives the muscle a behavior analogous to that of a mechanical spring. This "spring-like" behavior plays a key role in the maintenance of posture. It can also play a prominent role in the control of motion; One intriguing possibility which has been explored by several researchers is based on the observation that the spring-like effects of a group of muscles determine an equilibrium position (Feldman, 1966; Bizzi et al., 1976, 1978; Polit and Bizzi, 1978, 1979; Cooke, 1979; Kelso, 1977; Kelso and Holt, 1980; Schmidt and McGown, 1980). As a result, the central nervous system may execute a movement by generating the set of motoneuron activities needed to define a new equilibrium posture. Continuously varying the activities of the motoneurons will generate a time-sequence of equilibrium postures. One appealing aspect of this idea is that it permits a unified treatment of posture and movement (Bizzi et al., 1981a, b, 1982a, b, 1984; Hogan, 1982a, 1984c).

While the validity and generality of this description of posture and movement behavior is still a topic of research, it provides the motivation for the work presented here. This paper is based on the idea that in controlling posture and movement, the central nervous system may take advantage of the apparent mechanical behavior of the neuro-musculo-skeletal system, and considers its ramifications in the case of multiple degree of freedom posture and movement.

Spring-Like Behavior of a Multi-Joint Limb

The relation between force and displacement of the end-point of a limb (e.g. the wrist or hand) can be determined experimentally by displacing the end-point from an equilibrium position and measuring the resulting steady-state force opposing the displacement. Is this force-displacement relation "spring-like"? Because of the complexity of the interactions in even the simplest multiple degree of freedom system, appropriate mathematical tools must be used to address this question. It is first necessary to define the term "spring-

like" rigorously. The single most important property of a spring is that it stores elastic energy. This is the basis of a completely general definition of a spring which is used in physical system modelling (Paynter, 1961; Rosenberg and Karnopp, 1983). A spring is any object which is characterised by a relation, possibly nonlinear or even discontinuous, between force and displacement¹ such that the integral of force with respect to displacement – the stored elastic energy – is defined. This is the origin of the definition of spring-like behavior used in this paper. If any system exhibits a relation between force and displacement which satisfies this condition, it is spring-like. Note that no assumption of linearity is required. The force-displacement integral is a potential function analogous to elastic energy, but the system itself need not be energy conservative. The internal mechanics of muscle contraction involve thermodynamically non-conservative processes, but a single muscle, either with or without feedback, exhibits a nonlinear but integrable relation between force and length. By the above definition it is spring-like.

From this definition a test of the spring-like behavior of a multi-joint system can be formulated. Mathematically, the force-displacement relation is a vector field, (see Appendix I) and the requirement that a potential function be definable places quantifiable restrictions on its form. In a multiple degree of freedom system a displacement in one direction may cause a force to be exerted in another direction. A potential function can be defined if and only if a displacement of the end-point of the limb in one direction, say, outward from the body, would produce a component of force in another direction, say, laterally across the midline, which is *exactly equal* to the component of force in the outward direction produced by a lateral displacement. This is expressed mathematically as the requirement that the curl of the vector field be zero (see Appendix I).

To test the spring-like behavior of the neuro-muscular system experimentally, it is only necessary to consider small displacements about an equilibrium point. Although the force-displacement relation may be nonlinear for large displacements, for sufficiently small deviations about an equilibrium point it is approximately linear (see Appendix I)

$$\begin{bmatrix} F_x \\ F_y \end{bmatrix} = \begin{bmatrix} -K_{xx} - K_{xy} \\ -K_{yx} - K_{yy} \end{bmatrix} \begin{bmatrix} dx \\ dy \end{bmatrix} \quad (1)$$

F_x : Force in x direction

F_y : Force in y direction

¹ Throughout this paper the term force will refer to both forces and moments, and displacement will refer to both position and angle

dx : Displacement in x direction

dy : Displacement in y direction

$$-K_{xx} = \partial F_x / \partial x, \quad -K_{xy} = \partial F_x / \partial y$$

$$-K_{yx} = \partial F_y / \partial x, \quad -K_{yy} = \partial F_y / \partial y.$$

The form of this relation is the same when expressed in any coordinate frame. It may be written as follows:

$$\mathbf{F} = -\mathbf{K} \mathbf{dx} \quad (3)$$

\mathbf{F} : Force vector

\mathbf{dx} : Displacement vector

\mathbf{K} : Stiffness.

The stiffness \mathbf{K} , is represented by a matrix of coefficients. It can be partitioned into two components, one symmetric and one antisymmetric.

$$\mathbf{K} = \mathbf{K}_s + \mathbf{K}_a, \quad (4)$$

$$\mathbf{K}_s = (\mathbf{K} + \mathbf{K}^t) / 2 = \begin{bmatrix} K_{xx} & (K_{xy} + K_{yx}) / 2 \\ (K_{xy} + K_{yx}) / 2 & K_{yy} \end{bmatrix}, \quad (5)$$

$$\mathbf{K}_a = (\mathbf{K} - \mathbf{K}^t) / 2 = \begin{bmatrix} 0 & (K_{xy} - K_{yx}) / 2 \\ (K_{yx} - K_{xy}) / 2 & 0 \end{bmatrix}. \quad (6)$$

Superscript t denotes transpose.

The purely symmetric component, \mathbf{K}_s , represents the forces which have no curl and can be derived from a potential function. This is the spring-like part of the behavior. The antisymmetric component, \mathbf{K}_a , represents the forces which have non-zero curl and can not be derived from a potential function. Comparison of the relative magnitudes of the symmetric and antisymmetric components of the stiffness provides a numerical quantification of the extent to which the neuromuscular system is spring-like. Note that because this test requires the determination of the influence of displacements in one direction on the forces generated in another direction, it is only possible in a multiple degree of freedom system. The results of an investigation of multi-joint posture and movement have shown that in intact humans the curl term is small in comparison to the spring-like term, (Mussa-Ivaldi et al., 1984) confirming that for planar arm postures the behavior of the neuro-muscular system is predominantly spring-like.

The Role of Inter-Muscular Feedback

This rigorous definition of spring-like behavior leads to several interesting and useful conclusions. The potential at any point is a scalar, coordinate-invariant quantity which remains the same when expressed in

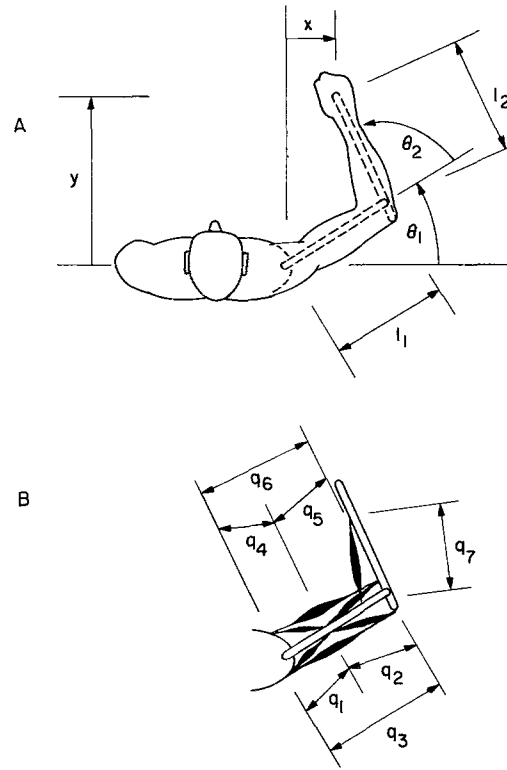

Fig. 1A and B. A sketch of a planar, two-segment model of the upper limb and some of the muscles attached to it. The geometric quantities describing the configuration of the skeleton are shown in part A; muscle lengths are depicted in part B

any coordinate frame. The relationship between force and displacement in any coordinate frame may therefore be obtained by finding the gradient of the total potential function with respect to that coordinate frame.

For example, consider the planar two-segment abstraction of the upper extremity (e.g. the forearm and arm) sketched in Fig. 1.

In this conceptual model, the skeletal segments are considered to be rigid bodies and the muscles are each assumed to have a single point of origin and insertion. The force-length behavior of the individual muscles defines a total potential which is a function of all of the muscle lengths.

$$f_i = f_i(q_i), \quad (7)$$

$$E_{pi}(q_i) = \int -f_i dq_i, \quad (8)$$

$$E_p(\mathbf{q}) = \sum_i E_{pi}(q_i) \quad (9)$$

f_i : Individual muscle forces

q_i : Individual muscle lengths

\mathbf{q} : Vector of muscle lengths

E_{pi} : Individual potential functions

E_p : Total potential function.

The muscle lengths are determined by the configuration of the limb, e.g. the joint angles, and thus the total spring-like effect of the muscles may be expressed (by simple substitution) as a scalar potential field defined on the joint coordinate space

$$q_i = q_i(\theta), \quad (10)$$

$$E_p(\mathbf{q}) = E_p[\mathbf{q}(\theta)] = E_p(\theta) \quad (11)$$

θ : Vector of joint angles.

The net torque-angle relation is then obtained by taking the gradient of the potential with respect to joint angle.

$$T_1 = -\partial E_p / \partial \theta_1, \quad (12)$$

$$T_2 = -\partial E_p / \partial \theta_2 \quad (13)$$

T_1 : Shoulder torque

T_2 : Elbow torque

θ_1 : Shoulder angular displacement

θ_2 : Elbow angular displacement.

Or, in vector notation,

$$\mathbf{T} = -\text{grad}_{\theta} E_p(\theta). \quad (14)$$

Given the kinematic relation between joint angles and the position of the end-point in extra-corporal coordinates (e.g. cartesian) the net effect of all of the muscles may also be expressed (by direct substitution) as a scalar potential field defined on the end-point coordinates and the net force-displacement relation at the end-point may then be obtained by taking the gradient of the potential with respect to the displacement of the end-point

$$\mathbf{x} = L(\theta); \quad \theta = L^{-1}(\mathbf{x}), \quad (15)$$

$$E_p(\theta) = E_p[L^{-1}(\mathbf{x})] = E_p(\mathbf{x}), \quad (16)$$

$$\mathbf{F} = -\text{grad}_{\mathbf{x}} E_p(\mathbf{x}) \quad (17)$$

$L(\)$: limb kinematic equations.

Summarising, because individual muscles may be described as spring-like, their combined effect will be to define a spring-like behavior for the end-point. Of course, the force-displacement relation for the limb depends also on feedback-generated interaction between muscles. This inter-muscular reflex action could introduce a force-displacement behavior with a non-zero curl component which could not be described as spring-like. In fact, a non-zero curl could *only* be produced by heteronymous inter-muscular reflex arcs with unequal gains, e.g. if stretch of the elbow muscles produced activation of the shoulder muscles which was stronger (or weaker) than the activation of the elbow muscles resulting from a corresponding stretch of the shoulder muscles.

In this way a multi-joint system presents new opportunities to investigate the role of feedback in the control of limb behavior: if a non-zero curl term is found experimentally in the force-displacement relation for the limb then it can not be attributed to any property of the individual muscles, or any effect of homonymous feedback, but must be due to heteronymous inter-muscular feedback action. Note that the converse is not true: zero curl does not preclude the action of inter-muscular feedback with equal gains. However, it is important to bear in mind that while the spring-like behavior of the total limb may in part be due to intrinsic properties of individual muscles and may in part be due to feedback action, the distinction between these two mechanisms will have no functional bearing on the mechanical behavior of the limb.

The Directional Character of Multi-Joint Stiffness

In a multiple degree of freedom system such as the arm with its muscles, the force-displacement behavior has a directional property; both the magnitude and the direction of the output force vector resulting from an input displacement vector of a given magnitude will depend on the orientation of the displacement vector.

One aspect of this directional character is expressed by the antisymmetric component of the stiffness, \mathbf{K}_a . It may be represented by the "pincushion" diagram of Fig. 2a in which the arrow depicting the force vector is drawn with its tail at the tip of the displacement vector.

The force due to this component is always directed at right angles to the displacement with a magnitude proportional to that of the displacement. The rotational character of this component of the total stiffness can clearly be seen and is the reason why it is referred to as the curl of the vector field.

The symmetric or spring-like component of the stiffness, \mathbf{K}_s , also has a directional property. It may be represented graphically in several ways: one is the pincushion diagram of Fig. 2b; another useful representation is derived from the potential function. As the force-displacement relation is approximately linear for small displacements, the corresponding potential function is a quadratic.

$$\begin{aligned} E_p &= -\mathbf{F}'\mathbf{dx} = 1/2 \mathbf{dx}'\mathbf{K} \mathbf{dx} \\ &= 1/2(K_{xx}dx^2 + K_{xy}dxdy + K_{yx}dxdy + K_{yy}dy^2). \end{aligned} \quad (18)$$

If the potential E_p is a constant, this is the equation of an ellipse. The potential function may be represented as a surface which looks like a valley or bowl (see Fig. 2c) with its bottom at the equilibrium point. "Vertical" sections through the potential function are

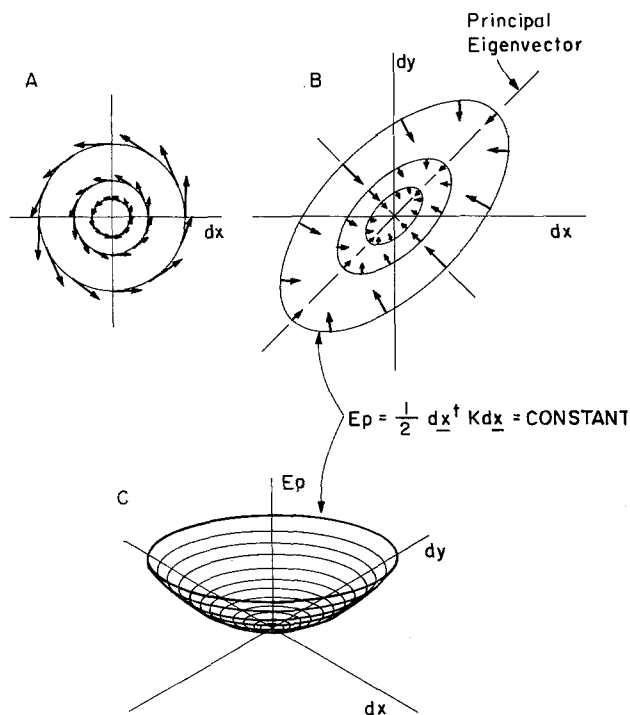

Fig. 2A–C. Graphical representations of a steady-state relation between force and displacement vectors. Part A shows an anti-symmetric stiffness of the form

$$\begin{bmatrix} F_x \\ F_y \end{bmatrix} = \begin{bmatrix} 0 & -1 \\ 1 & 0 \end{bmatrix} \begin{bmatrix} dx \\ dy \end{bmatrix}.$$

The output force vector is represented by an arrow drawn with its tail at the tip of the input displacement vector. Note the rotational character which is due to the non-zero curl of the vector relation. Part B depicts a symmetric stiffness of the form

$$\begin{bmatrix} F_x \\ F_y \end{bmatrix} = \begin{bmatrix} -5/2 & 3/2 \\ 3/2 & -5/2 \end{bmatrix} \begin{bmatrix} dx \\ dy \end{bmatrix},$$

using the same convention. In this case the vector relation is irrotational and has zero curl. A symmetric stiffness may also be represented by the potential function which it defines. Part C shows an oblique view of the potential function corresponding to the symmetric stiffness of part B which has the shape of a valley or bowl. The ellipses of parts B and C are isopotential contours; note that the force vectors are perpendicular to the isopotential contours. The eigenvectors of the stiffness are the directions in which the force and displacement vectors are co-linear. For this stiffness the eigenvalues are 1 and 4 respectively; note that the stiffness in the direction of the minor axis is four times smaller than in the direction of the major axis

parabola. “Horizontal” (isopotential) sections through the potential function are nested ellipses. The major axes of all of the elliptical isopotential contours coincide (see Fig. 2b). Mathematically, the orientation of the major axis is determined by a quantity known as the principal eigenvector of the stiffness \mathbf{K}_s . Its physical significance is that if the limb is displaced in this

direction then the restoring force acts in exactly the opposite direction. The same is true for displacements in the direction of the minor axis, which is also determined by an eigenvector of the stiffness. However, for displacements in any other direction the restoring force will not act in the opposite direction², but at an angle. In fact, as the restoring force vector is given by the gradient of the potential function, it will be oriented perpendicular to the elliptical isopotential contours (see Fig. 2b).

The magnitude of the restoring force also depends on the direction of the applied displacement. For displacements in the direction of the major axis, the magnitude of the restoring force is determined by a stiffness which is inversely proportional to the square root of the length of the major axis. Mathematically, the stiffness in this direction is determined by a quantity known as the principal eigenvalue of the stiffness. The stiffness in the direction of the minor axis is also an eigenvalue. A displacement in any other direction can be expressed as a vector sum of displacements along the major and minor axes and the resulting force determined as the vector sum of the restoring forces along the major and minor axes. Graphically, for displacements in any direction, the magnitude of the restoring force at any point is given by the steepness of the potential “valley” (closeness of the isopotential contours) at that point.

In short, in the multiple degree of freedom case spring-like behavior has a directional property which is specified by the eigenvectors of the symmetric component of the stiffness. The size and shape of the field of restoring forces are specified by the eigenvalues of the symmetric component of the stiffness. These quantities fully characterise the spring-like behavior. As discussed next, the directional property of the force-displacement behavior may prove to be important for controlling the interaction between a limb and its environment.

Modulating the Postural Response of the Limb

The forces generated by a limb in response to externally imposed displacements play a key role in determining how the limb will interact with objects in its environment. Dynamic interaction between a limb and its environment is the goal of a large class of purposeful acts; the use of a tool is one obvious example. When limb and environment interact the performance of the limb is profoundly affected and its stability may be jeopardised. Control strategies which are successful for

² Unless the eigenvalues of the stiffness are equal, in which case the principal axes cannot be uniquely defined

free motions may fail when the limb is coupled to its environment. To command position alone may suffice for reaching or pointing movements but it does not provide adequate control of dynamic interaction. Something beyond simple position (or force) control is required. One practical strategy (Hogan, 1980b, 1982b, 1983, 1984b, d, 1985) is to modulate the dynamic response of the limb to externally imposed disturbances. The neuro-muscular dynamics which generate forces in response to imposed displacements constitute a mechanical impedance, which can be thought of as a dynamic generalisation of the postural stiffness of the limb. What is required in general is the control and coordination of postural behavior.

Because of the physiology of muscle contraction, intrinsic muscle stiffness increases with increasing muscle force and in the presence of feedback the net stiffness of a single muscle also increases monotonically with the force output from that muscle (up to more than half of the range of physiological forces)³ (Wilkie, 1950; Joyce et al., 1969; Agarwal and Gottlieb, 1977; Zahalak and Heyman, 1979; Hoffer and Andreassen, 1981). Given that the stiffness of a single muscle increases with force, (whatever the mechanism) it is then possible for the net mechanical stiffness and, more generally, the mechanical impedance about a single joint to be modulated by coactivation of antagonist muscle groups (Vickers, 1968; Lanman, 1980). This may be one of the strategies used by the CNS to control postural behavior (Hogan, 1979, 1984a).

When this concept is generalised to the multi-joint case new factors emerge due to the geometry and kinematics of muscle attachment. One of the ways of controlling the postural behavior of a multi-joint limb would be to modulate the size, shape and orientation of its end-point stiffness. The end-point might be made compliant in one direction to accommodate an external kinematic constraint and stiff in another direction to minimise the effects of disturbing forces. Alternatively, it might be appropriate for the limb to present a uniform postural stiffness to disturbances in all directions. Either of these would require the ability to modulate all of the elements in the stiffness independently, including the off-diagonal terms representing the interaction between degrees of freedom.

If only those muscle groups spanning a single joint were available, synergistic muscle activation would not

3 In fact, a substantial body of evidence has been amassed in support of the postulate (Nichols, 1974; Nichols and Houk, 1973, 1976; Houk, 1979; Hoffer and Andreassen, 1981; Crago et al., 1976) that one of the functions of the spinal reflex arcs is to regulate or maintain the stiffness of a single muscle at a given force level in the face of disturbing influences such as the yield in muscle force which accompanies rapid muscle stretch

be able to modulate all of the terms in the stiffness; there would be no way to modulate the interaction between joints. However, many muscles cross more than one joint. These polyarticular muscles may serve a unique purpose: They provide precisely the coupling between joints needed to permit all of the elements in the stiffness to be modulated by muscle synergies (Hogan, 1980a, b, 1983).

For example, consider the spring-like behavior of the end-point of a planar two-segment model of the arm with polyarticular (two-joint) muscles included as shown in Fig. 3.

For clarity and simplicity, in this model the moment arms of all muscles will be assumed to be constant (an assumption valid for small motions) and the moment arms of the two-joint muscles, e.g. biceps and triceps, about the elbow and the shoulder are assumed to be equal. The lengths of the upper arm and

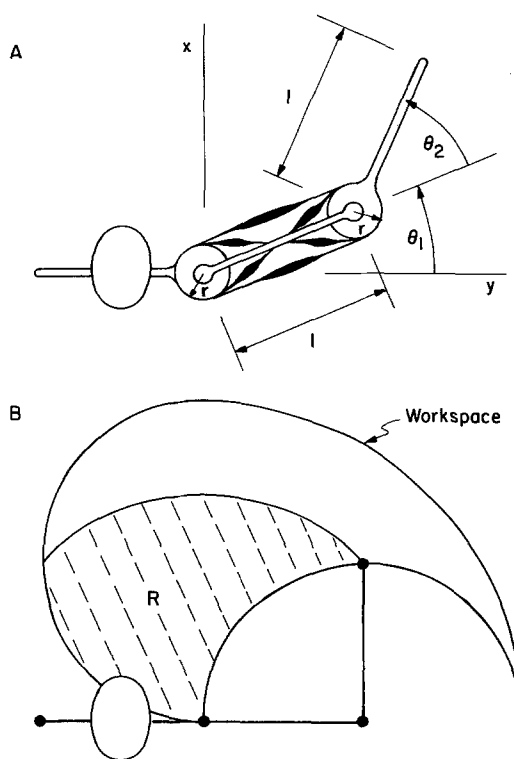

Fig. 3A and B. A sketch of a planar, two-segment model of the upper limb is shown in part A. Both single- and double-joint muscles are included but the geometry of muscle attachment has been simplified so that all muscles act with a constant radius, r , about the joints. Part B shows the workspace of the limb, the region which may be reached by the end-point, given that the shoulder angle may lie between 0 and 90 deg and the elbow angle may lie between 0 and 180 deg. Because of the two-joint muscles, an isotropic end-point stiffness may be achieved throughout the shaded region, R , by coordinated synergistic muscle activation. In the absence of two-joint muscles this is not possible at any point in the workspace

forearm are also assumed to be equal. Now suppose (for the purpose of discussion only) that the central nervous system wished to impose a uniform (isotropic) stiffness on the end-point, which would mean that an input displacement in any direction would produce a postural restoring force in exactly the opposite direction with a magnitude proportional to that of the displacement. The required end-point stiffness would be diagonal with equal terms

$$\begin{bmatrix} F_x \\ F_y \end{bmatrix} = \begin{bmatrix} -K_{xx} & 0 \\ 0 & -K_{yy} \end{bmatrix} \begin{bmatrix} dx \\ dy \end{bmatrix}, \quad (19)$$

where $K_{xx} = K_{yy} = K$, a constant.

The end-point stiffness and the corresponding joint stiffness are related through the Jacobian of the known kinematic relation between joint angles and end-point coordinates. The required stiffness in joint coordinates is: (see Appendix II).

$$\begin{bmatrix} T_1 \\ T_2 \end{bmatrix} = \begin{bmatrix} -K(l_1^2 + l_2^2 + l_1 l_2 \cos \theta_2) & -K(l_2^2 + l_1 l_2 \cos \theta_2) \\ -K(l_2^2 + l_1 l_2 \cos \theta_2) & -K l_2^2 \end{bmatrix} \begin{bmatrix} d\theta_1 \\ d\theta_2 \end{bmatrix}. \quad (20)$$

Note that the diagonal end-point stiffness requires a non-diagonal joint-coordinate stiffness. If only single joint muscles were present, the stiffness achieved by simultaneous synergistic activation of all of the muscles would be (in joint coordinates):

$$\begin{bmatrix} T_1 \\ T_2 \end{bmatrix} = \begin{bmatrix} -R_s & 0 \\ 0 & -R_e \end{bmatrix} \begin{bmatrix} d\theta_1 \\ d\theta_2 \end{bmatrix} \quad (21)$$

R_s : Angular stiffness due to single-joint shoulder muscles

R_e : Angular stiffness due to single-joint elbow muscles.

It can be seen that because of the absence of coupling between the joints (no off-diagonal terms) the isotropic end-point stiffness of Eq. (19) [which requires the joint coordinate stiffness of Eq. (20)] cannot be achieved.

In contrast, if the two-joint muscles are included, then the stiffness achieved by simultaneous synergistic activation of all of the muscles would be (in joint coordinates):

$$\begin{bmatrix} T_1 \\ T_2 \end{bmatrix} = \begin{bmatrix} -R_s - R_t & -R_t \\ -R_t & -R_e - R_t \end{bmatrix} \begin{bmatrix} d\theta_1 \\ d\theta_2 \end{bmatrix} \quad (22)$$

R_t : Angular stiffness due to two-joint muscles.

Because of the coupling due to the two-joint muscles, an isotropic end-point stiffness can now be

achieved throughout a large portion of the workspace, the shaded region R in Fig. 3 (see Appendix II).

The *quantitative* details of the results presented in Fig. 3 are sensitive to the assumptions made in their derivation. However, even if these assumptions are modified to better represent the true musculo-skeletal geometry, the *qualitative* results remain the same: the presence of polyarticular muscles dramatically increases the ability of the central nervous system to modulate the total end-point stiffness of the limb through coordinated synergistic muscle activation.

Dynamic Aspects of Postural Behavior

So far this paper has considered the relation between force and displacement. Muscle force also depends upon dynamic variables, for example, the velocity of muscle shortening (Hill, 1938; Katz, 1939; Wilkie, 1950; Bigland and Lippold, 1954; Joyce et al., 1969) and the force-displacement relation is only one aspect of the total effective mechanical behavior of the limb. These dynamic effects will play an important role in posture and movement.

In developing more general models of the mechanical behavior of a limb, it is important to realise that the neuro-muscular system is properly described as a mechanical impedance, (an object or system which accepts motion inputs and yields force outputs) whereas the skeleton is properly described as a mechanical admittance (an object or system which accepts force inputs and yields motion outputs). The importance of this distinction lies in the fact that if two systems (e.g. the muscles and the skeleton) are mathematically modelled by two sets of differential equations with no distinction made between admittance and impedance, then when the two systems are coupled such that the output of one is the input to the other (and vice versa), in general it may not be possible to write a single set of integrable and solvable differential equations to represent the behavior of the complete system (see Appendix III).

This is because a kinematically constrained mechanical linkage such as the skeleton may not, in general, allow an arbitrary displacement or motion to be imposed on it; A mathematical model of the linkage written with motion as the input variable may not be solvable for force as the output variable. On the other hand, an arbitrary force may be applied to the linkage; A mathematical model of the linkage with force as the input can always be solved for the resulting motion. A linkage is properly described as a mechanical admittance (Hogan, 1984b, d, 1985). If care is taken to preserve the distinction between impedance and admittance, a solvable set of differential equations may

always be written for the complete neuro-musculo-skeletal system (see Appendix III).

Because the dynamic equations describing the skeleton must see an input force, the neuro-muscular system must produce an output force; As the skeletal system is an admittance the neuro-muscular system must be an impedance. Any model of the neuro-muscular system, however complex, may always be written in a form which may be solved *explicitly* for the net force exerted on the skeletal linkage.

One useful consequence of this observation is the fact that the total impedance of all of the muscles and ligaments attached to the skeleton may be obtained by adding the component impedances *even when these component impedances are themselves nonlinear*. In Eqs. (7)–(9) this fact was used to find the net force-displacement behavior due to all of the muscles of a limb. In considering dynamic aspects of postural behavior it means that if the net behavior of the neuro-muscular system can be decomposed or “dissected” into individual components these may be recombined by simple addition *without any loss of generality*.

As a result, quite a general and powerful model of neuro-muscular behavior may be formulated by considering each muscle separately and describing its behavior as a series of components, the first being a relation between output force and input displacement, the second being a relation between output force and input velocity, and so on, each new component representing successively higher-order dynamic effects.

Accordingly, the velocity-dependent behavior of the neuro-muscular system may be treated as another component of the total impedance of the limb. All of the above discussion of the “spring-like” behavior of muscles may now be applied to the “viscous-like” behavior with the input velocity taking the place of the input displacement. Thus, although the velocity-dependent behavior of a single muscle may be nonlinear and may be due to sensory feedback loops or due to the intrinsic molecular mechanics of muscle contraction or due to passive tissue effects, it *must* be such that an input velocity defines an output force. As a result, a scalar potential function may be defined just as in the case of the length-dependent behavior. This potential function does not correspond to energy but has similar properties: It is a scalar function defined on the velocity space and it is invariant under a change of coordinates. If the net behavior of the system were only due to the simple aggregate of the individual muscle behaviors (of whatever origin) a total “viscous potential” function for the neuro-muscular system could be obtained by summing the component “viscous potential” functions of the individual muscles. The net velocity-dependent behavior in any coordinate frame could then be determined from the gradient of this

“viscous potential”. On the other hand, inter-muscular reflex feedback action with unequal gains could introduce a velocity-dependent force which would not be derivable from a potential function, i.e. a curl component. A linearised viscosity may be defined and partitioned into symmetric and antisymmetric components. Experimental measurement of the viscosity would permit a quantitative comparison of the relative magnitudes of the “viscous-like” forces derivable from a potential function and the forces due to a curl term which can only arise from asymmetric inter-muscular feedback action.

The velocity-dependent behavior has a directional property similar to that of the position-dependent behavior; the magnitude and direction of the output force vector depends on both the orientation and the magnitude of the input velocity vector. The directional character of the curl-free (viscous-like) velocity-dependent forces can be represented by the ellipsoid associated with the viscosity; its size, shape and orientation are characterised by the eigenvalues and eigenvectors of the viscosity. Modulating the size, shape and orientation of the end-point viscosity may be one of the strategies adopted by the CNS to control interaction with its mechanical environment. Given that the apparent viscosity of a single muscle (the slope of its force-velocity characteristic) increases with muscle force, (Bigland and Lippold, 1954; Joyce et al., 1969) coordinated synergistic activation of all of the muscles of a limb is one way to modulate the velocity-dependent behavior of the end-point of the limb (Vickers, 1968; Lanman, 1980). As with the stiffness, the presence of polyarticular muscles dramatically increases the extent to which the velocity-dependent component of postural behavior may be modulated through coordinated simultaneous activation of the muscles.

Modulation of Inertial Behavior

Another important component of the postural behavior of the limb is the relation between force and acceleration due to the inertia of the limb segments. If the displacement and velocity dependent behavior of the neuro-muscular system can be modulated, can the inertial behavior of the skeleton also be modulated? Unlike the mechanical parameters of muscle there is no known physiological process through which the central nervous system can voluntarily modulate the inertia of a single skeletal segment; However, once again, a multi-joint system is behaviorally richer than a single-joint system. A measure of control over the complete inertial behavior of a multi-joint limb is possible.

The apparent inertial behavior of a mechanical linkage such as the upper limb is characterised mathematically by its mobility tensor (Hogan, 1984b, d, 1985). Physically, if the limb is at rest (zero velocity) then an applied force vector causes an acceleration vector (not necessarily co-linear with the force) which is obtained by premultiplying the force vector by the mobility tensor (see Appendix IV). As with the stiffness and viscosity, the apparent inertial behavior of the end-point has a directional property; the magnitude and direction of the acceleration vector depends on both the orientation and magnitude of the applied force. For a two-segment model of the upper limb, (e.g. Figs. 1 or 3) this directional character depends strongly on the location of the end-point in the workspace. When the end-point is near the shoulder the acceleration in the radial direction will be large compared to the acceleration in the tangential direction (for an applied force of the same magnitude); The end-point is more mobile radially than tangentially. When the elbow is near full extension, the converse is true; The acceleration in the radial direction is small compared to the acceleration in the tangential direction (for an applied force of the same magnitude).

Because the apparent inertial behavior of the end-point depends on its position in the workspace, the central nervous system would gain a limited measure of control over the end-point mobility by choosing the location in the workspace at which to perform a manipulation. Of course, for a simple planar two-segment system, if the end-point location were not something the central nervous system could choose (as would be the case in many realistic situations) the mobility could not be modulated because once the end-point position has been specified the end-point mobility has been specified. However, in reality the upper extremity is not restricted in this way; the number of degrees of freedom in the upper extremity far exceeds the number of degrees of freedom required to describe the position of the hand in space. Looking from the sternum outwards there are at least 9 df in the skeleton supporting the hand,⁴ (12 or more if the motion of the scapula relative to the clavicle is considered) whereas the position of the hand in space has at most six degrees of freedom. The additional degrees of freedom give the central nervous system new behavioral options and can be used as "control inputs". The "kinematic redundancy" of the skeletal system provides a substantial measure of control over its end-point inertial behavior.

4 In this discussion the hand is considered to be a single rigid body and the degrees of freedom of the palm, the thumb and the fingers are being ignored

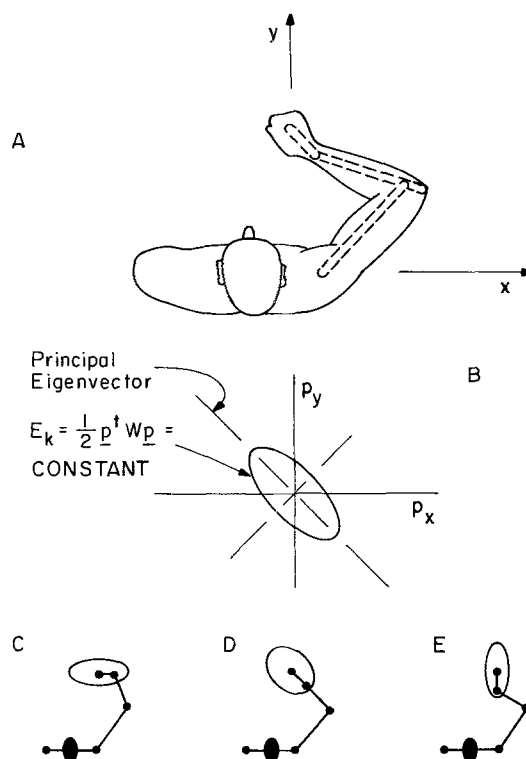

Fig. 4A-E. A sketch of a planar three-segment model of the upper limb is shown in part A. A graphical representation of the directional character of the apparent inertia of the end-point is shown in part B via the mobility ellipse, the locus of values of the end-point momentum vector for which the kinetic energy stored in the linkage is a constant. The eigenvectors of the mobility tensor, W , are the directions in which a force vector applied at the end-point when the limb is at rest will result in a co-linear acceleration vector. The lengths of the major and minor axes of the mobility ellipse are proportional to the square roots of the apparent mass of the limb in those directions. Parts C-E depict the way the apparent end-point inertia of a three-segment linkage changes with configuration while the location of its end-point remains the same. Note that the apparent mass in both the x and y directions changes by a factor of six between configurations C and E

For example, consider the planar three-segment model of the upper extremity (e.g. arm, forearm and hand) shown in Fig. 4.

If the orientation of the hand is neglected, only two quantities are required to specify the location of the end-point, whereas three joint angles are required to define the configuration of the linkage. As in the two-segment case the apparent inertial behavior of the end-point is a function of the configuration of the limb and because of the "extra" degree of freedom, the configuration of the limb may be used to modulate the effective end-point mobility even when the location of the end-point is fixed. For a given position of the end-point, as the wrist is rotated the mobility in any given direction undergoes a substantial change. For some orientations

Table 1. Variation of the apparent end-point mass of a three-segment planar linkage due to configuration changes

Distal link orientation [deg]	Apparent mass x-direction	Apparent mass y-direction
	[kg]	
90	0.322	1.823
135	0.568	0.568
180	1.823	0.322

Each segment is assumed to be a uniform rod of linear density 1 kg/m. Segment lengths are 1, 2, and 3 m respectively

of the wrist a perturbing force directed towards the shoulder joint is resisted primarily by the rotational inertia of the hand and the effective end-point mobility is large; for other orientations of the wrist the motion of the end-point in response to the same perturbing force is resisted by the inertia of the hand, the forearm and the upper arm and the effective end-point mobility is reduced. To demonstrate the magnitude of this effect, Table 1 shows the values of the apparent end-point mass of a simple three-segment linkage composed of uniform rods of linear density 1 kg/m and lengths 1, 2, and 3 m respectively. As the distal link rotates through ninety degrees, the end-point location remaining unchanged, the apparent mass in each of the two orthogonal directions changes by a factor of six.

A graphical picture of the effective inertial behavior of the skeleton is available which closely parallels that used to represent the spring-like behavior of the neuromuscular system. The inertial behavior of any mechanical system is properly defined through the storage of kinetic energy (see Appendix III). As kinetic energy is a scalar, invariant under any coordinate transformation, the total effective inertial behavior may be described in any coordinate frame. The mobility tensor in end-point coordinates is related to the mobility tensor in joint coordinates through the Jacobian (see Appendix IV).

$$\mathbf{W} = \mathbf{J}\mathbf{Y}\mathbf{J}'$$

W: End-point coordinate mobility tensor

Y: Joint-coordinate mobility tensor

J: Jacobian.

This equation determines the end-point mobility even when the Jacobian is not square and does not have an inverse, as is the case when the linkage degrees of freedom exceed the end-point degrees of freedom. Because the skeleton is a mechanical linkage which can only store energy, not supply or dissipate it, the mobility is symmetric and, as with the stiffness and

viscosity, can be used to define an ellipse. This ellipse depicts the directional character of the effective inertial behavior, as shown in Fig. 4. The eigenvalues and eigenvectors of the symmetric mobility tensor determine its size, shape and orientation. The eigenvectors represent directions in which a force applied when the system is at rest will result in an instantaneous acceleration co-linear with the force. In any other direction the impressed force and the resulting acceleration will not be co-linear⁵. Each eigenvalue represents the mobility (inverse mass) in the direction of the corresponding eigenvector. The length of the major (and minor) axis of the ellipse is proportional to the square root of the effective mass in that direction. Figure 4 shows how the ellipse associated with the end-point mobility of a linkage composed of three uniform rods of linear density 1 kg/m and lengths 1, 2, and 3 m respectively changes with configuration as its end-point location remains constant.

In summary, the central nervous system may modulate its inertial behavior by repositioning the limb. The ability to modulate the inertial behaviour or mechanical admittance of the skeleton complements the ability to modulate the mechanical impedance (stiffness, viscosity, etc.) of the neuromuscular system. Modulating both admittance and impedance permits control and regulation of the entire postural behaviour of the limb and this suggests the interesting possibility that the impedance (e.g. stiffness, viscosity) and admittance (e.g. inertia) may be coordinated in some way by the central nervous system to yield a desired postural behaviour. Some preliminary results of an investigation of this possibility are presented by Mussa-Ivaldi et al. (1984).

"Redundancy" or excess degrees of freedom increase the extent to which the mobility of the limb can be modulated. In general, the greater the number of joints, the greater the freedom of choice. Excess degrees of freedom have an equally strong influence on the total effective stiffness and viscosity of the limb. Because of this, changing the configuration of the limb may prove to be the dominant mechanism for modulating the directional aspects of its stiffness and viscosity as well as its mobility. In considering the control of posture and movement, the geometry or configuration of the limb should be regarded as a "control input" on par with alpha-motoneuron activity. Taking advantage of musculo-skeletal geometry to facilitate the maintenance of posture or the control of movement is only possible in a multi-joint system and any question about the extent to which the central nervous system exercises this option cannot be addressed in single-joint studies.

⁵ Unless the eigenvalues are identical

The Relation of Posture to Movement

The previous sections examined the postural behavior (stiffness, viscosity, mobility) of a multi-joint limb. Movement of a multi-joint limb may also be described in the same unified framework by extending some results derived from single-joint studies. The spring-like behavior of the neuro-muscular system is the key: it defines an equilibrium posture for the limb as a function of the neuro-muscular activity. As the neuro-muscular activity varies, a sequence of equilibrium positions may be defined, thereby generating a movement. In the multi-joint case the potential function defined by the spring-like behavior may be envisioned as a "valley" with the equilibrium position of the limb at its bottom (Hogan, 1980a, b, 1983). As the neuro-muscular activity varies this equilibrium position may be moved through the workspace and as a result the limb will move so as to approach that equilibrium position. A useful graphic image is that of a deformable surface containing a movable depression. The behavior of the limb is analogous to that of a ball rolling on this deformable surface. The ball will tend to seek the lowest point on the surface but that point may move ahead of it or behind it, thereby generating the forces required to accelerate and decelerate the ball. The viscous-like forces are analogous to a sticky coating on the rolling ball, which will always tend to decelerate it.

This unified treatment of posture and movement through the spring-like behavior of the muscles has been successfully applied in the single-joint case. It has been shown (Bizzi et al., 1976; Polit and Bizzi, 1978, 1979) that the postures at the beginning and end of a single-joint point-to-point movement are in stable equilibrium (even in the absence of reflex feedback). A subsequent study (Bizzi et al., 1984) has shown that the trajectory between these points also exhibits stable equilibrium behavior; if the limb is disturbed during a movement it tends to return to the trajectory of an unperturbed motion rather than proceed directly to the target position. The simple assumption that movement could be generated by continuously varying the equilibrium position defined by the neuro-muscular activity was used in a computer simulation which successfully predicted all of the major qualitative and quantitative features of the observed perturbed and unperturbed movements (Hogan, 1984c).

In extending this unified treatment of posture and movement to the multi-joint case the potential function not only provides a description of the forces causing movement, it describes the stability of the trajectory. Again the image of a ball rolling on a deformable surface is useful: following a disturbance encountered when the moving depression is in transit

between the start and target positions, the ball will tend towards the point defined by the current position of the depression rather than the target position. Because of the dynamic forces governing its behavior (e.g. viscosity, inertia, etc.) the ball need not move directly towards the bottom of the "valley" (i.e. its velocity vector need not point towards the current location of the time-varying equilibrium position). Indeed, if the deformable surface were shaped so as to define an elongated valley oriented along the line joining the start and target positions, the ball would tend to fall down the sides of the valley before moving along its length towards the target, and in this way it would tend to return to the original undisturbed trajectory (Hogan, 1980a, b, 1983). In the case of the moving limb, forces tending to make it deviate from the base of the valley, such as those due to the coriolis and centrifugal accelerations, would be resisted by the steepness of the valley walls.

The time-varying equilibrium posture defined by the synergistic action of the muscles⁶ may be thought of as that position towards which the net muscular activity is driving the limb at any point in time. It is a summary statement of *one* of the mechanical effects of the net neuro-muscular activity. As it is merely a convenient descriptive device it need not correspond to the actual position of the limb, and in fact need not even lie within the workspace of the limb. For this reason, it has been termed the "virtual position" (Hogan, 1984c; Bizzi et al., 1984). During movement it will in general differ from the actual position as the detailed time-course of the movement will be determined by the interaction between the inertia of the limb and the impedance of the neuro-muscular system; when posture is achieved the virtual and actual positions coincide. From this perspective, posture may be regarded as a special (or degenerate) case of movement.

The movable and deformable potential valley is a *completely general* representation of the modulation of the spring-like behavior of the neuro-muscular system by the neural commands. Does it lead to new insights? One interesting question is: Does spring-like behavior permit the central nervous system to adopt simplifying control strategies? One such strategy would be to pre-plan a virtual trajectory in work-space coordinates which proceeded from start to target and also pre-plan an impedance (e.g. a potential valley plus any higher-order terms) to provide a measure of stability to that virtual trajectory. Because of the stability provided by

⁶ Note that this description of the moving limb as being driven toward a varying equilibrium position may be used even if the force displacement behavior of the neuro-muscular system were to include a curl term

the neuro-muscular impedance the actual trajectory would be relatively insensitive to errors in knowledge of the initial position or even to errors in knowledge of the limb dynamics. This type of control strategy is in sharp contrast to the conventional approach to robot movement control. It is generally perceived (Paul, 1981) that fast and accurate computation to solve a complicated set of kinematic and dynamic equations describing the robot is necessary to generate coordinated movements. These are the so-called "inverse kinematics" and "inverse dynamics" problems of robotics and it has been suggested (Hollerbach, 1982) that they are fundamental to biological movement control. However, using the above approach the inverse kinematics problem can be eliminated completely (Hogan and Cotter, 1982; Hogan, 1984b, d, e, 1985) and, given appropriate neuro-muscular stiffnesses and viscosities, accurate and detailed precomputation of the nonlinear inertial dynamic interaction forces (due to coriolis and centrifugal accelerations) would not be necessary (Hogan, 1980a, b, 1983, 1984d, e) to achieve the approximately straight movements of the hand which are typically observed (Abend et al., 1982). The validity of this control strategy as a description of the behavior of the central nervous system is presently under investigation. A recent computer simulation study which was based on experimentally derived musculo-skeletal parameters showed good agreement with experimental observations (Flash and Mussa-Ivaldi, 1984). The power and practicality of this control strategy has been demonstrated by applying it to a simple robotic manipulator and achieving "sophisticated" behavior, including point-to-point motion, constrained motion, and avoidance of unpredictably-moving objects, using an "unsophisticated" controller based on simple 8-bit, 2-MHz microprocessors (Andrews and Hogan, 1983).

Conclusion

Consideration of the control of multi-joint posture and motion opens up a vast (and largely unexplored) area of research into the neurophysiology of motor control. New and qualitatively different experiments become possible in the multi-joint case. For example, an experimental quantification of the extent to which the neuro-muscular system exhibits spring-like behavior is obtainable from the relative magnitudes of the symmetric and antisymmetric components of the stiffness and measurement has confirmed that the system is, in fact, predominantly spring-like (Mussa-Ivaldi et al., 1984).

New insights into the possible function of musculo-skeletal structures may be gained. For example,

polyarticular muscles dramatically increase the extent to which coordinated synergistic activation of the muscles may modulate the impedance of the end-point of the limb.

New insights into the role of neural feedback emerge. Any curl term in the force-displacement (or force-velocity) behavior of the limb can only be due to heteronymous inter-muscular feedback. Furthermore, measurement of the stiffness (and viscosity) permits a numerical quantification of the roles of neural feedback vs. intrinsic muscular properties in the control of posture and movement which is not possible in the single-joint case.

New behavioral possibilities emerge. For example, while no physiological process is available for voluntary modulation of the inertial behavior of a single limb segment, the effective end-point mobility of a multi-joint limb may be modulated. In essence, in the multi-joint case the geometry or configuration of the musculoskeletal system becomes one of the "inputs" available to modulate and control the system behavior.

New perspectives on motor coordination by the central nervous system emerge. Because multi-joint stiffness (and viscosity and inertial) is characterised by a shape and orientation as well as a magnitude, it can be seen that the postural behavior of a multi-joint system may be coordinated by the central nervous system. Coordinating postural behavior will play an important role in controlling tasks such as the use of a tool which require dynamic interaction between limb and its environment.

Note that the difference between limb and environment is primarily a descriptive distinction and modulating the complete dynamic behavior of the limb may simplify unperturbed movement control. The environment of the forearm includes the hand and any objects grasped by it, but also includes the arm and the other connected body segments. Dictating the impedance of a limb segment specifies its response to "environmental" inputs; This could be used to produce a coordinated interaction between limb segments without the need for continuous intervention from the higher controlling levels of the central nervous system. This "passive coordination" could be generalised to control the interaction between two limbs (or more – consider the fingers and thumb) or to control the interaction of two (or more) limbs mechanically coupled across a grasped object such as a tool.

Some well-established ideas about the role of the nervous system may need to be re-thought. Apparent redundancies or excess degrees of freedom in the musculo-skeletal system (i.e. the presence of more muscles than there are joints, the presence of more joints in the arm than the degrees of freedom specifying the position of the hand) complicate the control of

undisturbed movements and it is commonly perceived that one of the functions of the neural circuitry is to simplify the control of movement by imposing "neural constraints" to reduce the number of degrees of freedom (Bernstein, 1967). Rather than presenting a problem which the motor controller must solve, they may offer a solution to the problem of controlling interactive behavior. By selectively reconfiguring the limb or synergistically coactivating appropriate groups of muscles it may be possible for the central nervous system to modulate or control the net dynamic behavior of the limb seen at the end-point.

Conversely, new limitations on the performance of the system may be identified. Controlling the complete dynamic behavior of the limb may be beyond the capacity of the central nervous system. The simplest possible (linearised) description of the dominant (second order) dynamic behavior of the neuro-musculo-skeletal system which drives the hand requires (symmetric) six-dimensional stiffness, viscosity and mobility matrices. Even these quantities, which are simplified representations of the true behavior, require 21 independent parameters *each*, a total of 63, to be completely defined. If the disturbance is sufficiently abrupt, then, because of the inevitable transmission delays, continuous intervention based on neural feedback information will not be a feasible method of modulating these quantities (e.g. consider the impact processes involved in catching an object or wielding a hammer). In this case the intrinsic properties of the musculoskeletal system provide the *only* vehicle for modulating the total dynamic behavior. The system may not be sufficiently redundant to accomplish this.

Unfortunately, many of the problems of multi-joint control are intrinsically complex and must be approached with care. If valuable insight is not to be lost, mathematical techniques of sufficient power and generality must be used in their analysis. The techniques used in the work reported in this paper and elsewhere (Hogan, 1980b, 1982b, 1983, 1984a-e, 1985) are an attempt to develop a systematic approach to these problems and offer a unified framework in which to consider posture and movement. Despite its formidable complexity, the study of multi-joint posture and movements is an important aspect of motor neurophysiology. It offers an unparalleled opportunity to learn about the organisation and function of the central nervous system.

Appendix I

From the definition of spring-like behaviour, force, \mathbf{F} , is an explicit function of position, \mathbf{x} . This function defines a vector field:

$$\mathbf{F} = \mathbf{F}(\mathbf{x}). \quad (\text{A1})$$

In addition, this function must be integrable to define a potential function, E_p :

$$E_p(\mathbf{x}) = \int -\mathbf{F}^t d\mathbf{x} = \int dE_p(\mathbf{x}), \quad (\text{A2})$$

$$\mathbf{F}(\mathbf{x}) = -\text{grad } E_p(\mathbf{x}). \quad (\text{A3})$$

In planar cartesian coordinates:

$$\mathbf{x} = \begin{bmatrix} x \\ y \end{bmatrix} \quad \mathbf{F} = \begin{bmatrix} F_x \\ F_y \end{bmatrix} = \begin{bmatrix} F_x(x, y) \\ F_y(x, y) \end{bmatrix}, \quad (\text{A4})$$

$$-\text{grad } E(x, y) = \begin{bmatrix} -\frac{\partial E_p}{\partial x} \\ -\frac{\partial E_p}{\partial y} \end{bmatrix} = \begin{bmatrix} F_x(x, y) \\ F_y(x, y) \end{bmatrix}. \quad (\text{A5})$$

The curl of the vector field is defined as:

$$\text{curl } \mathbf{F}(x, y) = \frac{\partial F_x}{\partial y} - \frac{\partial F_y}{\partial x}. \quad (\text{A6})$$

From the definition of a potential function,

$$\text{curl grad } E_p(x, y) = 0. \quad (\text{A7})$$

A necessary and sufficient condition for the vector field $\mathbf{F}(x, y)$ to be spring-like is:

$$\text{curl } \mathbf{F}(x, y) = 0. \quad (\text{A8})$$

The vector field may be nonlinear. If it is sufficiently differentiable in the neighbourhood of a point (x_0, y_0) it may be expanded as a Taylor series.

$$F_x = F_x(x_0, y_0) + \frac{\partial F_x}{\partial x}(x_0, y_0) dx + \frac{\partial F_x}{\partial y}(x_0, y_0) dy + \text{higher order terms}, \quad (\text{A9})$$

$$F_y = F_y(x_0, y_0) + \frac{\partial F_y}{\partial x}(x_0, y_0) dx + \frac{\partial F_y}{\partial y}(x_0, y_0) dy + \text{higher order terms}. \quad (\text{A10})$$

At an equilibrium position $F_x(x_0, y_0) = F_y(x_0, y_0) = 0$. For sufficiently small displacements from equilibrium, the higher order terms may be neglected, and the force-displacement relation is linear to a first-order approximation.

$$\begin{bmatrix} F_x \\ F_y \end{bmatrix} = \begin{bmatrix} -K_{xx} & -K_{xy} \\ -K_{yx} & -K_{yy} \end{bmatrix} \begin{bmatrix} dx \\ dy \end{bmatrix} \quad (\text{A11})$$

$$-K_{xx} = \frac{\partial F_x}{\partial x} \quad -K_{xy} = \frac{\partial F_x}{\partial y}$$

$$-K_{yx} = \frac{\partial F_y}{\partial x} \quad -K_{yy} = \frac{\partial F_y}{\partial y}.$$

If the curl of the vector field is zero,

$$-K_{xy} = \frac{\partial F_x}{\partial y} = \frac{\partial F_y}{\partial x} = -K_{yx}, \quad (\text{A12})$$

and the stiffness $\mathbf{K} = \begin{bmatrix} K_{xx} & K_{xy} \\ K_{yx} & K_{yy} \end{bmatrix}$ is symmetric.

Appendix II

An isotropic end-point stiffness corresponds to a stiffness tensor with equal eigenvalues.

$$\begin{bmatrix} F_x \\ F_y \end{bmatrix} = \begin{bmatrix} -K & 0 \\ 0 & -K \end{bmatrix} \begin{bmatrix} dx \\ dy \end{bmatrix}, \quad (\text{A13})$$

$$\mathbf{F} = -\mathbf{K} d\mathbf{x}. \quad (\text{A14})$$

The transformation from joint coordinates to end-point coordinates is:

$$x = l_1 \cos \theta_1 + l_2 \cos(\theta_1 + \theta_2), \quad (\text{A15})$$

$$y = l_1 \sin \theta_1 + l_2 \sin(\theta_1 + \theta_2) \quad (\text{A16})$$

l_1 : length of link 1

l_2 : length of link 2.

The differential transformation from joint coordinates to end-point coordinates is:

$$dx = -l_1 \sin \theta_1 d\theta_1 - l_2 \sin(\theta_1 + \theta_2)(d\theta_1 + d\theta_2), \quad (\text{A17})$$

$$dy = l_1 \cos \theta_1 d\theta_1 + l_2 \cos(\theta_1 + \theta_2)(d\theta_1 + d\theta_2). \quad (\text{A18})$$

In a more compact notation:

$$\begin{bmatrix} dx \\ dy \end{bmatrix} = \begin{bmatrix} -l_1 s_1 - l_2 s_{12} & -l_2 s_{12} \\ l_1 c_1 + l_2 c_{12} & l_2 c_{12} \end{bmatrix} \begin{bmatrix} d\theta_1 \\ d\theta_2 \end{bmatrix} \quad (\text{A19})$$

$$s_1 : \sin \theta_1 \quad s_{12} : \sin(\theta_1 + \theta_2)$$

$$c_1 : \cos \theta_1 \quad c_{12} : \cos(\theta_1 + \theta_2).$$

The configuration-dependent differential transformation matrix is called the Jacobian, \mathbf{J}

$$d\mathbf{x} = \mathbf{J} d\boldsymbol{\theta}. \quad (\text{A20})$$

An incremental change in potential energy will be the same in all coordinates.

$$dE_p = -\mathbf{T}' d\boldsymbol{\theta} = -\mathbf{F}' d\mathbf{x} = -\mathbf{F}' \mathbf{J} d\boldsymbol{\theta}. \quad (\text{A21})$$

Thus the transformation from end-point force to joint torque is:

$$\mathbf{T} = \mathbf{J}' \mathbf{F}. \quad (\text{A22})$$

Using Eqs. (A22), (A14), and (A20), the transformation from end-point stiffness, \mathbf{K} , to joint-coordinate stiffness, \mathbf{R} , is:

$$\mathbf{T} = -\mathbf{R} d\boldsymbol{\theta} = -\mathbf{J}' \mathbf{K} \mathbf{J} d\boldsymbol{\theta}, \quad (\text{A23})$$

$$\mathbf{R} = \mathbf{J}' \mathbf{K} \mathbf{J}. \quad (\text{A24})$$

Using Eq. (A19) and the trigonometric identity $s_1 s_{12} + c_1 c_{12} = c_2$, the joint-coordinate stiffness required to produce the isotropic end-point stiffness of Eq. (A13) is:

$$\mathbf{R} = K \begin{bmatrix} l_1^2 + l_2^2 + 2l_1 l_2 c_2 & l_2^2 + l_1 l_2 c_2 \\ l_2^2 + l_1 l_2 c_2 & l_2^2 \end{bmatrix}. \quad (\text{A25})$$

The joint-coordinate stiffness due to simultaneous synergistic activation of single-joint shoulder and elbow muscles and two-joint muscles is:

$$\mathbf{R} = \begin{bmatrix} R_s + R_t & R_t \\ R_t & R_e + R_t \end{bmatrix}. \quad (\text{A26})$$

If an isotropic end-point stiffness is to be achieved, Eqs. (A25) and (A26) must be identical. The following three simultaneous equations must be satisfied:

$$R_s = K(l_1^2 + l_1 l_2 c_2), \quad (\text{A27})$$

$$R_e = -K l_1 l_2 c_2, \quad (\text{A28})$$

$$R_t = K(l_2^2 + l_1 l_2 c_2). \quad (\text{A29})$$

In the absence of two-joint muscles $R_t = 0$.

Aside from the trivial case $K = R_e = R_s = R_t = 0$, if $l_1 = l_2$, no solution exists if $R_t = 0$.

In contrast, in the presence of two-joint muscles, assuming R_e, R_s , and R_t are non-negative and $l_1 = l_2$, an isotropic end-point stiffness can be achieved in the region

$$90^\circ < \theta_2 < 180^\circ. \quad (\text{A30})$$

Appendix III

If the neuromusculoskeletal system is described as a state-determined system, the equations will have the following general form:

$$\dot{\mathbf{s}} = f(\mathbf{s}, t) \quad (\text{A31})$$

\mathbf{s} : vector of state variables

t : time

$f(\)$: algebraic function.

The complete system may be partitioned into two interacting state-determined subsystems (e.g. the skeleton and the neuromuscular system) such that:

$$\mathbf{s} = \begin{bmatrix} \mathbf{s}_1 \\ \mathbf{s}_2 \end{bmatrix} \quad (\text{A32})$$

\mathbf{s}_1 : state vector of subsystem 1

\mathbf{s}_2 : state vector of subsystem 2.

If each subsystem is written in general state-determined form without regard to the distinction between impedance and admittance, the system equations will have the following form:

$$\text{Subsystem 1: } \dot{\mathbf{s}}_1 = f_1(\mathbf{s}_1, \mathbf{u}_1, t) \quad (\text{A33})$$

$$\mathbf{r}_1 = g_1(\mathbf{s}_1, \mathbf{u}_1, t) \quad (\text{A34})$$

\mathbf{u} : vector of inputs to subsystem 1.

\mathbf{r} : vector of outputs from subsystem 1.

$g_1(\)$: algebraic function

$$\text{Subsystem 2: } \dot{\mathbf{s}}_2 = f_2(\mathbf{s}_2, \mathbf{u}_2, t) \quad (\text{A35})$$

$$\mathbf{r}_2 = g_2(\mathbf{s}_2, \mathbf{u}_2, t). \quad (\text{A36})$$

The two subsystems interact such that the output of one is the input to the other and vice-versa

$$\mathbf{u}_1 = \mathbf{r}_2, \quad (\text{A37})$$

$$\mathbf{u}_2 = \mathbf{r}_1. \quad (\text{A38})$$

Unfortunately, it is in general not possible to reassemble Eqs. (A33) through (A38) into the form of Eq. (A31). To do so it is necessary to express the inputs \mathbf{u}_1 and \mathbf{u}_2 as *explicit* functions of

the states \mathbf{s}_1 and \mathbf{s}_2 and time. However, combining Eqs. (A34), (A36), (A37), and (A38) yields an *implicit* form

$$\mathbf{u}_1 = g_2(\mathbf{s}_2, g_1(\mathbf{s}_1, \mathbf{u}_1, t), t), \quad (\text{A39})$$

$$\mathbf{u}_2 = g_1(\mathbf{s}_1, g_2(\mathbf{s}_2, \mathbf{u}_2, t), t). \quad (\text{A40})$$

Without further knowledge of the form of the algebraic functions $g_1(\cdot)$ and $g_2(\cdot)$ it is in general not possible to express Eqs. (A39) and (A40) in explicit form.

Closer examination of the subsystems provides the necessary additional information. If the skeleton is assumed to be composed of rigid bodies kinematically constrained relative to one another, it is a generalised inertial system. The defining property of an inertial system is its ability to store kinetic energy, defined as the integral of (generalised) velocity with respect to (generalised) momentum (Crandall et al., 1968). At any configuration defined by generalised coordinates, θ , (e.g. joint angles) the kinetic energy, E_k , is a quadratic form in momentum, \mathbf{h}

$$E_k(\theta, \mathbf{h}) = 1/2 \mathbf{h}' \mathbf{Y}(\theta) \mathbf{h}. \quad (\text{A41})$$

$\mathbf{Y}(\theta)$ is the symmetric, twice-contravariant mobility tensor (Hogan, 1984). It is the inverse of the inertia tensor (Crandall et al., 1968) and in general changes with configuration.

The rigid-body assumption means that the kinetic energy is also the total energy of the skeletal system and is equal to its Hamiltonian. The system equations may then be written in the generalised Hamiltonian form (Stiefel and Scheifele, 1971) as follows:

$$d\theta/dt = \text{grad}_{\mathbf{h}} E_k(\theta, \mathbf{h}), \quad (\text{A42})$$

$$d\mathbf{h}/dt = - \text{grad}_{\theta} E_k(\theta, \mathbf{h}) + \mathbf{T}. \quad (\text{A43})$$

\mathbf{T} is a vector of generalised forces or torques. Equations (A42) and (A43) are the state equations corresponding to Eq. (A33) with θ and \mathbf{h} as the states

$$\mathbf{s} = \begin{bmatrix} \theta \\ \mathbf{h} \end{bmatrix}. \quad (\text{A44})$$

The generalised velocity, ω , is found from Eqs. (A41) and (A42)

$$\omega = \mathbf{Y}(\theta) \mathbf{h}. \quad (\text{A45})$$

Equation (A45) is the output equation corresponding to Eq. (A34).

The generalised inertial system described by Eqs. (A42), (A43), and (A45) is a mechanical admittance with force (torque) input and motion (velocity) output. The output Eq. (A45) does not depend directly on the input, that is, it has the general form:

$$r_1 = g_1(\mathbf{s}_1, t). \quad (\text{A46})$$

Because of this, Eqs. (A33), (A46), and (A35) through (A38) may now be expressed in the form of Eq. (A31) by simple substitution

$$\dot{\mathbf{s}}_1 = f_1(\mathbf{s}_1, g_2(\mathbf{s}_2, g_1(\mathbf{s}_1, t), t), t), \quad (\text{A47})$$

$$\dot{\mathbf{s}}_2 = f_2(\mathbf{s}_2, g_1(\mathbf{s}_1, t), t). \quad (\text{A48})$$

Appendix IV

The inertial behaviour of a mechanical linkage such as the skeleton is characterised by the mobility tensor, \mathbf{Y} , which relates

generalised velocity, ω , to generalised momentum, \mathbf{h} [see Eq. (A45)]. To express this tensor in any other coordinates (e.g. end-point cartesian coordinates) it is sufficient to know the geometric relation between coordinate frames, e.g. Eqs. (A15) and (A16). Differentiating these equations yields the configuration-dependent relation between joint velocity and end-point velocity, \mathbf{v}

$$\mathbf{v} = \mathbf{J} \omega. \quad (\text{A49})$$

An incremental change in kinetic energy will be the same in all coordinates, and this can be used to determine the relation between joint momentum and end-point momentum, \mathbf{p}

$$dE_k = \mathbf{h} \mathbf{h}' \omega = d\mathbf{p}' \mathbf{v} = d\mathbf{p}' \mathbf{J} \omega, \quad (\text{A50})$$

$$d\mathbf{h} = \mathbf{J}' d\mathbf{p}. \quad (\text{A51})$$

At any given configuration, the Jacobian is constant and the differential relation of Eq. (A51) may be integrated to yield the transformation:

$$\mathbf{h} = \mathbf{J}' \mathbf{p}. \quad (\text{A52})$$

The relation between the end-point mobility tensor, \mathbf{W} , and the joint-coordinate mobility, \mathbf{Y} , is obtained using Eqs. (A49), (A45), and (A52)

$$\mathbf{v} = \mathbf{W} \mathbf{p} = \mathbf{J} \mathbf{Y} \mathbf{J}' \mathbf{p}, \quad (\text{A53})$$

$$\mathbf{W} = \mathbf{J} \mathbf{Y} \mathbf{J}'. \quad (\text{A54})$$

The physical meaning of the end-point mobility tensor is that if the system is at rest an applied force will produce an acceleration vector equal to the force vector premultiplied by the mobility tensor. At rest, $d\theta/dt = 0$, thus from Eqs. (A49) and (A45):

$$d\mathbf{v}/dt = \mathbf{J} d\omega/dt, \quad (\text{A55})$$

$$d\omega/dt = \mathbf{Y} d\mathbf{h}/dt. \quad (\text{A56})$$

Because the mobility tensor \mathbf{Y} is positive definite, Eq. (A45) shows that at rest, $\mathbf{h} = 0$. As a result, $E_k = 0$ [Eq. (A41)] and using Eq. (A22) in Eq. (A43) yields

$$d\mathbf{h}/dt = \mathbf{J}' \mathbf{F}. \quad (\text{A57})$$

Combining (A55), (A56), and (A57)

$$d\mathbf{v}/dt = \mathbf{J} \mathbf{Y} \mathbf{J}' \mathbf{F} = \mathbf{W} \mathbf{F}. \quad (\text{A58})$$

Acknowledgements. This research was supported by National Institute of Neurological and Communicative Disorders and Stroke Research Grant No. 5 R01 NS 09343 13, National Institute of Arthritis, Metabolism and Digestive Diseases Grant No. AM 26710 and National Science Foundation Research Grant No. ECS 8307461.

I am indebted to Doctors Emilio Bizzi, Ferdinando Mussa-Ivaldi and William Chapple for their many insightful comments on this work.

References

- Abend, W., Bizzi, E., Morasso, P.: Human arm trajectory formation. *Brain* **105**, 331–348 (1982)
- Agarwal, G.C., Gottlieb, G.L.: Compliance of the human ankle joint. *J. Biomech. Eng.* **99**, 166–170 (1977)
- Andrews, J.R., Hogan, N.: Impedance control as a framework for implementing obstacle avoidance in a manipulator. In:

- Control of manufacturing processes and robotic systems. pp. 243–251. Hardt, D.E., Book, W.J., eds. New York: American Society of Mechanical Engineers 1983
- Bernstein, N.A.: The co-ordination and regulation of movements. New York: Pergamon Press 1967
- Bigland, B., Lippold, O.C.J.: The relation between force, velocity and integrated electrical activity in human muscles. *J. Physiol.* **123**, 214–224 (1954)
- Bizzi, E., Polit, A., Morasso, P.: Mechanisms underlying achievement of final head position. *J. Neurophysiol.* **39**, 435–444 (1976)
- Bizzi, E., Dev, P., Morasso, P., Polit, A.: Effect of load disturbances during centrally initiated movements. *J. Neurophysiol.* **41**, 542–556 (1978)
- Bizzi, E., Accornero, N., Chapple, W., Hogan, N.: Processes underlying arm trajectory formation in monkeys. In: Brain mechanisms of perceptual awareness and purposeful behavior. pp. 311–318. Ajmone-Marson, C., Pompeiano, O., eds. New York: Raven Press 1981a
- Bizzi, E., Accornero, N., Chapple, W., Hogan, N.: Central and peripheral mechanisms in motor control. In: New perspectives in cerebral localization. pp. 23–24. Thompson, R.A., Green, J.R., eds. New York: Raven Press 1981b
- Bizzi, E., Chapple, W., Hogan, N.: Mechanical properties of muscles: implications for motor control. *Trends in Neurosci.* **5**, No. 11, 395–398 (1982a)
- Bizzi, E., Accornero, N., Chapple, W., Hogan, N.: Arm trajectory formation in monkeys. *Exp. Brain Res.* **46**, 139–143 (1982b)
- Bizzi, E., Accornero, N., Chapple, W., Hogan, N.: Posture control and trajectory formation during arm movement. *J. Neurosci.* **4**, 2738–2744 (1984)
- Cooke, J.D.: Dependence of human arm movements on limb mechanical properties. *Brain Res.* **165**, 366–369 (1979)
- Crago, P.E., Houk, J.C., Hasan, Z.: Regulatory actions of the human stretch reflex. *J. Neurophysiol.* **39**, 925–935 (1976)
- Crandall, S.H., Karnopp, D.C., Kurtz, E.F., Jr., Pridmore-Brown, D.C.: Dynamics of mechanical and electromechanical systems. New York: McGraw-Hill 1968
- Feldman, A.G.: Functional tuning of the nervous system with control of movement or maintenance of a steady posture. III. Mechanographic analysis of the execution by man of the simplest motor tasks. *Biophysics* **11**, 766–775 (1966)
- Flash, T., Mussa-Ivaldi, F.A.: Inferring movement and muscle synergies from multi-joint arm posture. *Neurosci. Abstr.* **10**, 635 (1984)
- Gordon, A.M., Huxley, A.F., Julian, F.J.: The variation in isometric tension with sarcomere length in vertebrate muscle fibers. *J. Physiol.* **184**, 170–192 (1966)
- Hill, A.V.: Heat of shortening and the dynamic constants of muscle. *Proc. R. Soc. (London) B* **126**, 136–195 (1938)
- Hoffer, J.A., Andreassen, S.: Regulation of soleus muscle stiffness in premammillary cats: intrinsic and reflex components. *J. Neurophysiol.* **45**, 267–285 (1981)
- Hogan, N.: Adaptive stiffness control in human movement. In: 1979 advances in bioengineering. pp. 53–54. Wells, M.K., ed. New York: American Society of Mechanical Engineers 1979
- Hogan, N.: Tuning muscle stiffness can simplify control of natural movement. In: 1980 advances in bioengineering. pp. 279–282. Mow, V.C., ed. New York: American Society of Mechanical Engineers 1980a
- Hogan, N.: Mechanical impedance control in assistive devices and manipulators. Proc. 1980 Joint Autom. Controls Conf. paper TA 10-B (1980b)
- Hogan, N.: Control and coordination of voluntary arm movements. Proc. 1982 Am. Control Conf. **1**, 552–558 (1982a)
- Hogan, N.: Programmable impedance control of industrial manipulators. pp. 186–191. Proc. Conference on CAD/CAM in Mechanical Engineering. Massachusetts Institute of Technology, Cambridge 1982b
- Hogan, N.: Mechanical impedance control in assistive devices and manipulators. In: Robot motion: planning and control. pp. 361–371. Brady, M., Hollerbach, J.M., Johnson, T.L., Lozano-Perez, T., Mason, M.T., eds. Cambridge: MIT Press 1983
- Hogan, N.: Adaptive control of mechanical impedance by coactivation of antagonist muscles. *IEEE Trans. AC-29*, 681–690 (1984a)
- Hogan, N.: Impedance control of industrial robots. *Robotics Comput.-Integr. Manuf.* **1**, 97–113 (1984b)
- Hogan, N.: An organising principle for a class of voluntary movements. *J. Neurosci.* **4**, 2745–2754 (1984c)
- Hogan, N.: Impedance control: an approach to manipulation. Proc. 1984 Am. Control Conf. **1**, 304–313 (1984d)
- Hogan, N.: Some computational problems simplified by impedance control. Proc. 1984 ASME Conf. Comput. Eng. **1**, 203–209 (1984e)
- Hogan, N.: Impedance control: an approach to manipulation. Part I: Theory; Part II: Implementation; Part III: Application. *ASME J. Dyn. Sys., Meas. Control* **107**, 1–24 (1985)
- Hogan, N., Cotter, S.L.: Cartesian impedance control of a nonlinear manipulator. In: Robotics research and advanced applications. pp. 121–128. Book, W.J., ed. New York: American Society of Mechanical Engineers 1982
- Hollerbach, J.M.: Computers, brains and the control of movement. *Trends Neurosci.* **6**, 189–192 (1982)
- Houk, J.C.: Regulation of stiffness by skeletomotor reflexes. *Annu. Rev. Physiol.* **41**, 99–114 (1979)
- Joyce, G., Rack, P.M.H., Westbury, D.R.: The mechanical properties of cat soleus muscle during controlled lengthening and shortening movements. *J. Physiol.* **204**, 461–474 (1969)
- Katz, B.: The relation between force and speed in muscular contraction. *J. Physiol.* **96**, 45–64 (1939)
- Kelso, J.A.S.: Motor control mechanisms underlying human movement reproduction. *J. Exp. Psychol.* **3**, 529–543 (1977)
- Kelso, J.A.S., Holt, K.G.: Exploring a vibratory system analysis of human movement production. *J. Neurophysiol.* **43**, 1183–1196 (1980)
- Lanman, J.M.: Movement and the mechanical properties of the intact human elbow joint. Ph. D. Dissertation, Department of Psychology, Massachusetts Institute of Technology 1980
- Matthews, P.B.C.: The dependence of tension upon extension in the stretch reflex of the soleus muscle of the decerebrate cat. *J. Physiol.* **147**, 521–546 (1959)
- Mussa-Ivaldi, F.A., Hogan, N., Bizzi, E.: Neural and geometric factors subserving arm posture. *J. Neurosci.* (1984, in press)
- Nichols, T.R.: Soleus muscle stiffness and its reflex control. Ph. D. Dissertation, Harvard University 1974
- Nichols, T.R., Houk, J.C.: Reflex compensation for variations in the mechanical properties of muscle. *Science* **181**, 182–184 (1973)
- Nichols, T.R., Houk, J.C.: Improvement in linearity and regulation of stiffness that results from actions of stretch reflex. *J. Neurophysiol.* **39**, 119–142 (1976)
- Paul, R.P.C.: Robot manipulators: mathematics, programming, and control. Cambridge: MIT Press 1981

- Paynter, H.M.: Analysis and design of engineering systems. Cambridge: MIT Press 1981
- Polit, A., Bizzi, E.: Processes controlling arm movements in monkeys. *Science* **102**, 1235–1237 (1978)
- Polit, A., Bizzi, E.: Characteristics of motor programs underlying arm movements in monkeys. *J. Neurophysiol.* **42**, 183–194 (1979)
- Rack, P.M.H., Westbury, D.R.: The effects of length and stimulus rate on tension in the isometric cat soleus muscle. *J. Physiol.* **204**, 443–460 (1969)
- Rosenberg, R.C., Karnopp, D.C.: Introduction to physical system dynamics. New York: McGraw-Hill 1983
- Schmidt, R.A., McGown, C.: Terminal accuracy of unexpectedly loaded rapid movements: evidence for a mass-spring mechanism in programming. *J. Motor Behav.* **12**, 149–161 (1980)
- Stiefel, E.L., Scheifele, G.: Linear and regular celestial mechanics. Berlin, Heidelberg, New York: Springer 1971
- Vickers, W.H.: A physiologically based model of neuromuscular system dynamics. *IEEE Trans. Man Machine Sys.* 21–23 (1968)
- Wilkie, D.R.: The relation between force and velocity in human muscles. *J. Physiol.* **110**, 249 (1950)
- Zahalak, G.I., Heyman, S.J.: A quantitative evaluation of the frequency response characteristics of active human skeletal muscle in vivo. *J. Biomech. Eng.* **101**, 28–37 (1979)

Received: April 15, 1985

Prof. N. Hogan
Massachusetts Institute of Technology
Department of Mechanical Engineering
Cambridge
MA 02139
USA